

PVC Gasketed & Solvent Weld Sewer Fittings



About Royal Building Products

Our company is part of a new corporation, Axiall, formed by a merger of Georgia Gulf and PPG's chlor-alkali and derivatives operations. Axiall is a Fortune 500-size company with revenues of \$5B+ headquartered in Atlanta, Georgia. The Royal Building Products Group markets a diverse portfolio of PVC building materials to both the consumer and professional segments. Some of these products are pipe and fittings, vinyl siding and trim, decorative moldings, decking, and windows and doors. The vertical integration we have with our parent company, Axiall, allows us to have access to best-in-class compounds and ongoing R&D.

For over **45** years, Royal Plastic Trends fittings have been specified and installed in municipalities nationwide. Headquartered in Shelby Township, MI, our company has a long tradition of leadership and innovation in PVC fittings. We develop, design, manufacture, market and distribute gasketed and solvent weld fittings for the municipal, plumbing and electrical markets. In our market segments, we offer the largest portfolio of injection molded fitting configurations in the industry, over **40%** more than any other manufacturer. With over **22** warehouses across the country, we enable the timely shipment of a broad assortment of products to your location or jobsite. Royal is **100%** committed to excellence in customer service.

We strive to exceed the expectations of the contractor community and ensure a quality fitting that will withstand the harsh environment of today's construction and perform on the job for years to come. As a result, many of our fittings carry **Triple Certification Listing**; NSF, UPC and CSA. Our company continues to expand its product lines and services to meet the emerging needs of our customers.

All of our fittings are engineered with their end-use in mind. Some of our key design advantages are reinforced wall thicknesses at important branch intersections, a robust, sealing gasket that prevents infiltration and ex-filtration, and square pipe stops which prevent over insertion. The result is a fitting that is well-built and reliable like no other on the market.

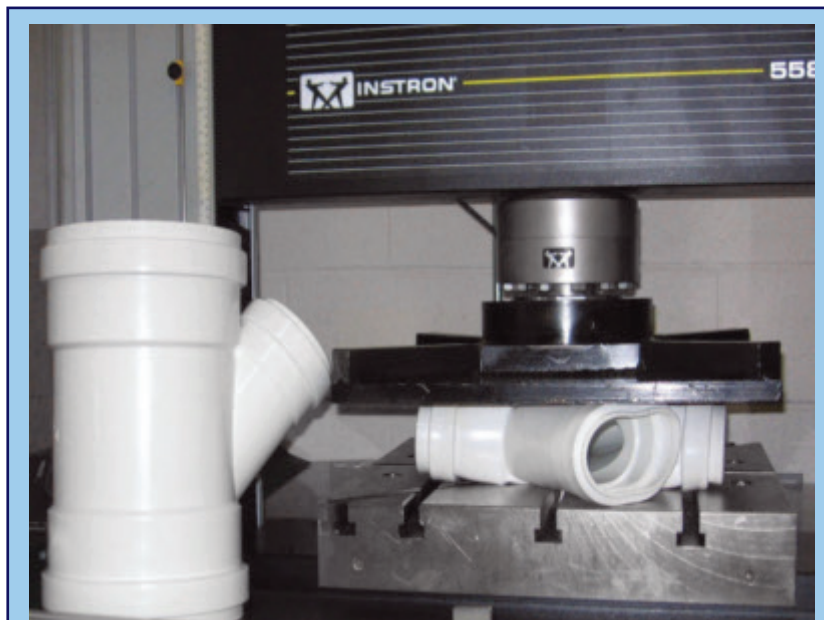

SDR 35 and SDR 26 fittings are tested to compress 60% without rupturing or cracking



Royal Municipal & Plumbing Products

G-Series Gasketed Sewer Fittings SDR 35	2-3
H-Series Gasketed Sewer Fittings SDR 26	4-5
P-Series Solvent Weld Sewer Fittings SDR 35	6-7
M-Series Solvent Weld Sewer Fittings SDR 26	8-9
Vertical Riser Systems	10-11
T-Series Gasketed IPS Drainage Fittings (Class 160)	12-13
C-Series Gasketed CIOD Pressure Fittings (DR18 & DR25)	14-15
N-Series Gasketed CIOD Non-Pressure Fittings (DR25)	16-17
K-Series PVC Profile Fittings SDR 35	18-19
Backwater Valves	20-21
D-Series Solvent Weld DWV Fittings	22-23
E-Series Electrical Solutions	24

Attention: Royal Building Product's fittings are not to be used or tested with compressed air or gases.

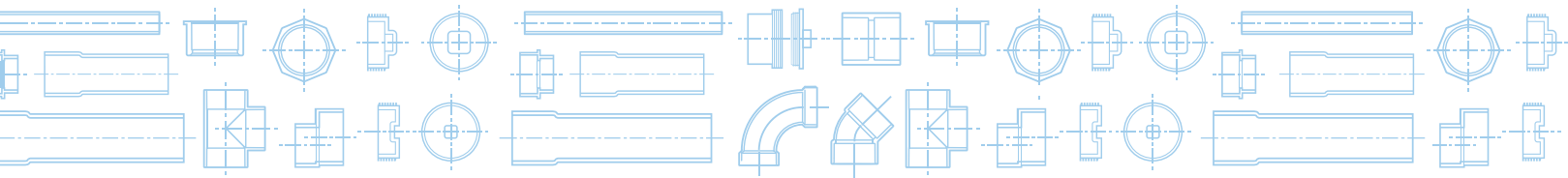

SDR 35 PVC Gasketed Sewer Fittings

**Injection Molded in Sizes 4" - 12"
Fabricated in Sizes 15" - 36"**

Our SDR 35 gasketed sewer fittings are designed for maximum performance in the most demanding environments along with ease of installation. Heavy duty reducing branches utilizing a minimum of SDR 18 wall thickness are used in injection molded 8", 10", and 12" tees, wyes, and tee-wyes to reinforce the strength of important branch intersections. A robust, high-performance gasket protects the system by preventing infiltration and ex-filtration.

Special features are incorporated to facilitate assembly; an extended pre-alignment lead in which aids in the proper placement of pipe and fittings, and our square pipe stop which resists pipe push-through from over insertion.

Our backwater valves are designed to be integrated with this series.

Design Advantages

- Reinforced wall thickness at key branch intersections to SDR 18 for added protection from stress and breakage. Injection molded joint withstands 50 psi hydrostatic pressure and 22" mercury vacuum pressure
- Integrated engineered gasket and a one-piece bell for maximum system performance
- Specially-designed square pipe stop prevents damage from over insertion, requires 30% more force before spearing
- Pre-alignment lead in allows an easy and timely installation
- **Triple certification listing**

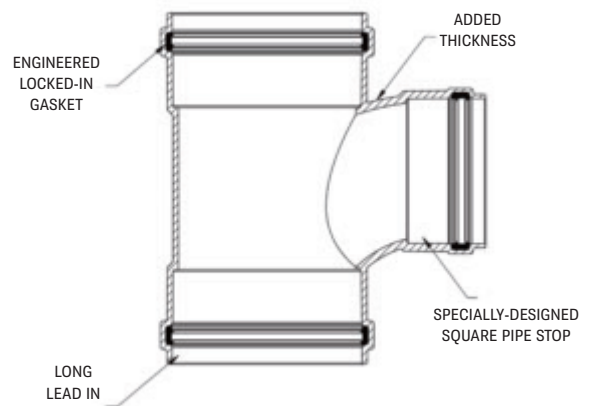

Applications

Non-pressure drainage of sewer and surface water.

Typical Uses:

Lateral Connections to Municipal Sewers

Sanitary
Storm

Surface Drainage

Area drainage
Parking lot drainage

Attention: Royal Building Product's fittings are not to be used or tested with compressed air or gases.

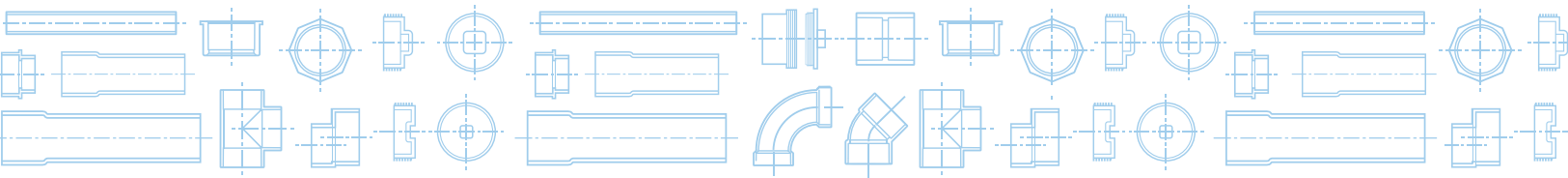

G-Series

The G series fitting line is a fully-integrated SDR 35 fitting design using reinforced branches and intersections to enhance the structural integrity of the installation and provide long-lasting performance.



Short Form Specifications

4" through 12" injection molded gasketed SDR 35 sewer fittings shall be manufactured in accordance with ASTM D3034, ASTM F1336, and CSA B182.2. They shall be injection molded from virgin PVC compound having a cell classification of 12454 or 13343 in accordance with, and certified by the National Sanitation Foundation (NSF), to meet ASTM D1784. Gaskets shall be manufactured in accordance with ASTM F477 or ASTM F913. Gaskets shall be firmly seated in fitting in order to ensure proper installation and to prevent dislocation or misalignment during system assembly. Gasket joints must comply with ASTM D3212 Internal Pressure Test (ex-filtration) and Vacuum Test (infiltration) at 5 degrees of gasket joint deflection and top load deflection.

Where available, reducing branches on injection molded 8", 10", and 12" tees, wyes, and tee-wyes shall be minimum SDR 18 wall thickness in the reducing branch body and reducing branch hub area below the gasket race.

Gasketed SDR 35 sewer fittings shall be certified by the National Sanitation Foundation (NSF) and, in applicable configurations, by the International Association Of Plumbing And Municipal Officials (IAPMO) to meet ASTM D3034, and by the Canadian Standards Association (CSA) to meet CSA B182.2.

Certification

Our Gasketed SDR 35 Sewer fittings are third party tested and listed by NSF, UPC and CSA to meet specifications defined in ASTM D3034, ASTM F1336 and CSA B182.2, where applicable.



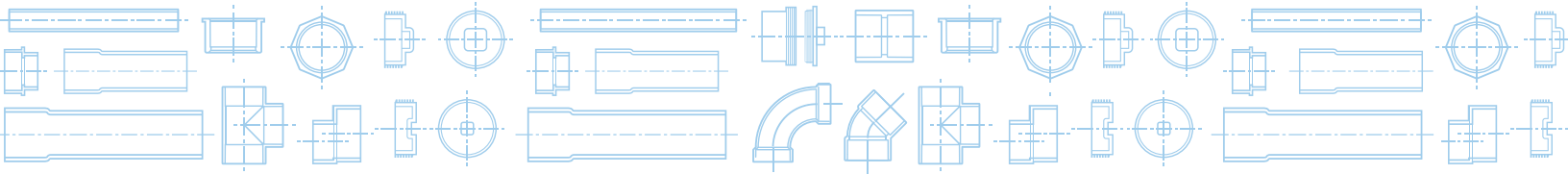

SDR 26 PVC Heavy Wall Gasketed Sewer Fittings

**Injection Molded in Sizes 4" - 12"
Fabricated in Sizes 15" - 36"**

SDR 26 extra heavy duty gasketed sewer fittings are designed for maximum performance in the toughest environments with a reinforced wall that is 34.5% thicker than SDR 35, and a superior, high impact, gasket retention ring. Heavy duty reducing branches utilizing a minimum of SDR 18 wall thickness are used in our injection molded 8", 10", and 12" tees, wyes, and tee-wyes to reinforce the strength of important branch intersections.

The gasket and shock absorbing properties of the gasket retention ring combine to reduce the effect of impact on 4" to 8" sizes for a more resilient system. A special collar design permanently locks the gasket onto the fitting ensuring a secure fit and a robust seal that prevents infiltration and ex-filtration. To make it easy to identify in the field, the collar and ring are a distinctive green color. A deep lead into the gasket enhances assembly and reduces the possibility of gasket damage or rolling, and our square pipe stop resists pipe push-through from over insertion.

Our vertical riser system utilizes many H Series components for a complete sewer protection solution.

Design Advantages

- Heavy duty, shock-absorbing collar designed to permanently lock the gasket onto the fitting, and inhibit fittings breaking under impact
- Specially-designed square pipe stop prevents damage from over insertion, requires 30% more force before spearing
- Reinforced wall thickness at key branch intersections for added strength. Injection molded joint withstands 200 psi hydrostatic pressure and 22" mercury vacuum pressure
- Distinctive green high impact retention rings and gaskets for easy identification in the field

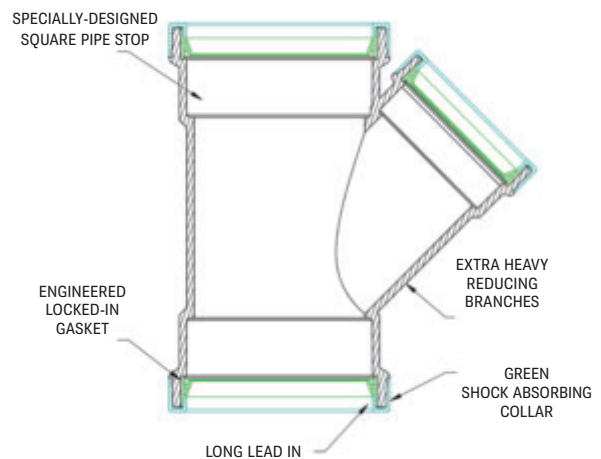

Applications

Non-pressure drainage of sewer and surface water wherever extra heavy SDR 26 is specified.

Typical Uses:

Lateral Connections to Municipal Sewers

Sanitary
Storm

Surface Drainage

Area drainage
Parking lot drainage

Attention: Royal Building Product's fittings are not to be used or tested with compressed air or gases.

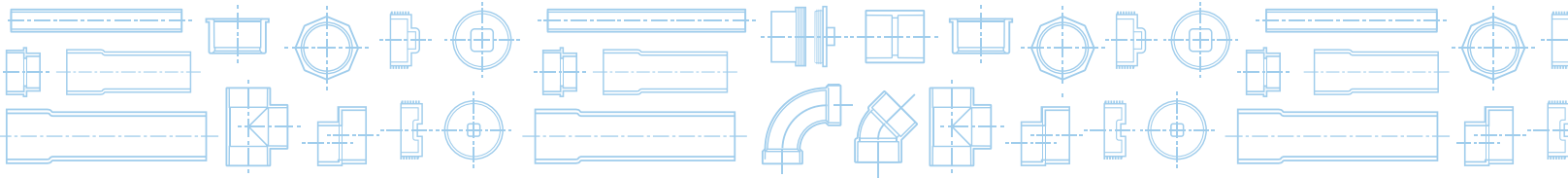

H-Series

The H series fitting line is a fully-integrated SDR 26 fitting design using reinforced branches and intersections to enhance the structural integrity of the installation and provide long-lasting performance.



Short Form Specifications

4" through 12" injection molded gasketed SDR 26 sewer fittings shall be manufactured in accordance with ASTM D3034, ASTM F1336 and CSA B182.2. They shall be injection molded from virgin PVC compound having a cell classification of 12454 or 13343 in accordance with, and certified by the National Sanitation Foundation (NSF), to meet ASTM D1784. Gaskets shall be manufactured in accordance with ASTM F477 or ASTM F913. Gaskets shall be firmly seated in fitting in order to ensure proper installation and to prevent dislocation or misalignment during system assembly. Gasket joints must comply with ASTM D3212 Internal Pressure Test (ex-filtration) and Vacuum Test (infiltration) at 5 degrees of gasket joint deflection certified at 200 psi and a 22" mercury vacuum pressure.

Where available, reducing branches on injection molded 8", 10", and 12" tees, wyes, and tee-wyes shall be minimum SDR 18 wall thickness in the reducing branch body and reducing branch hub below the gasket race.

Gasketed SDR 26 sewer fittings shall be certified by the National Sanitation Foundation (NSF) and, in applicable configurations, to meet ASTM D3034, and by the Canadian Standards Association (CSA) to meet CSA B182.2.

Certification

Our Gasketed SDR 26 Molded Sewer fittings are third party tested and listed by NSF and CSA to meet specifications defined in ASTM D3034, F1336 and CSA B182.2, where applicable.



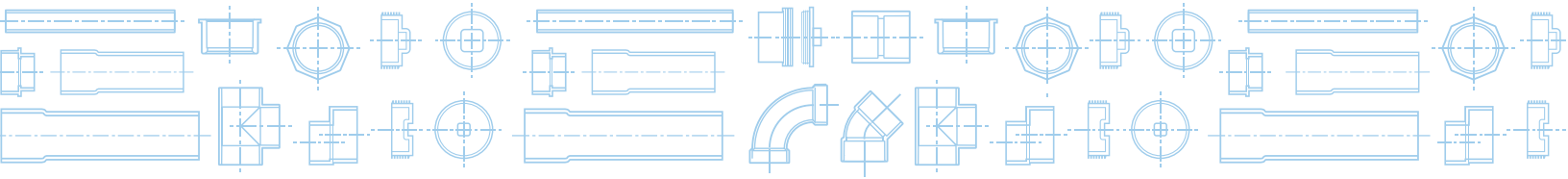

SDR 35 Solvent Weld Sewer Fittings

**Injection molded in 3" - 12"
Fabricated in Sizes 10" - 36"**

Our SDR 35 solvent weld sewer fittings are engineered for maximum performance in the most demanding environments and ease of installation. They are designed and manufactured to consistent dimensions and laying lengths to deliver a securely sealed, water-tight joint connection on every installation. Only virgin compounds are used in our injection molding process to ensure the highest quality and durability.

All fittings are thoroughly tested for joint tightness, internal stress, stability, color and uniformity. SDR 35 solvent weld sewer fittings conform to all municipal, federal, and military requirements and are available in a wide range of sizes.

Our PVC backwater valves are designed to be integrated with this series.

Design Advantages

- Designed for easy assembly
- Highest quality materials for long lasting performance
- Consistent dimensions provide joint integrity
- Broadest offering in the industry
- **Triple certification listing**

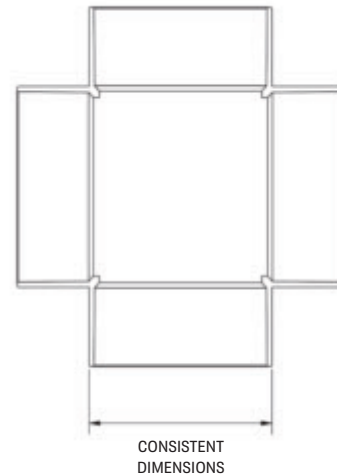

Applications

Non-pressure drainage of sewer and surface water.

Typical Uses:

Onsite Disposal

- Closed loop septic fields
- Open septic fields
- Engineered systems

Lateral Connections to Municipal Sewers

- Sanitary
- Storm

Surface Drainage

- Foundation drains
- Radon gas venting
- Yard drainage

Attention: Royal Building Product's fittings are not to be used or tested with compressed air or gases.

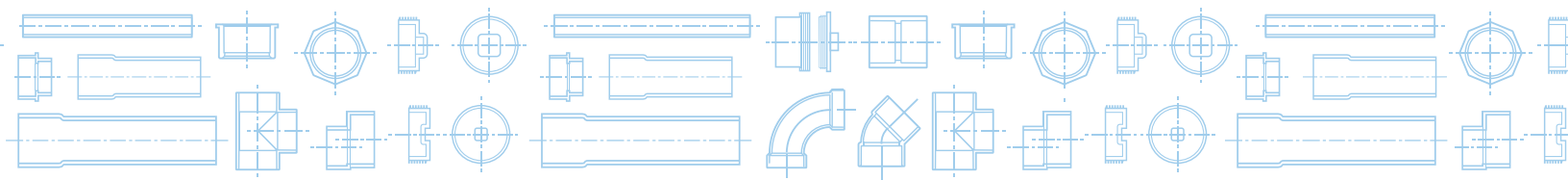

P-Series

The P series is an SDR 35 solvent weld sewer fitting line developed with structural integrity for easy assembly.



Short Form Specifications

4" through 12" injection molded solvent weld SDR 35 sewer fittings shall be manufactured in accordance with ASTM D3034 and CSA B182.2. They shall be injection molded from virgin PVC compound having a cell classification of 12454 or 13343 in accordance with, and certified by the National Sanitation Foundation (NSF), to meet ASTM D1784.

SDR 35 Solvent Weld fittings shall be certified by the National Sanitation Foundation (NSF) and, in applicable configurations, by the International Association Of Plumbing And Municipal Officials (IAPMO) to meet ASTM D3034, and by the Canadian Standards Association (CSA) to meet CSA B182.2.

Certification

Our Solvent Weld SDR 35 Sewer fittings are third party tested and listed by NSF, UPC and CSA to meet specifications defined in ASTM D3034 and CSA B182.2, where applicable.



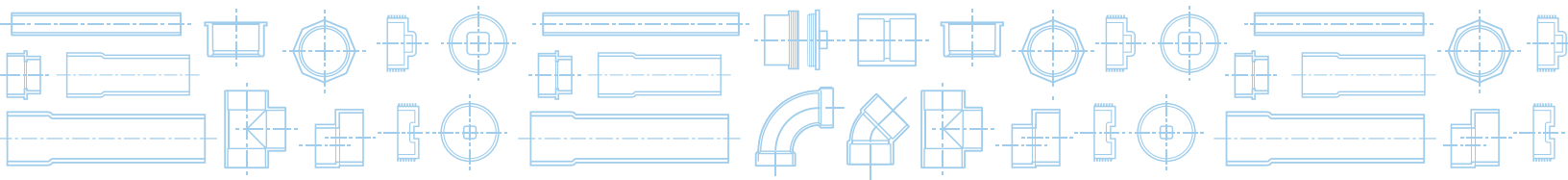

SDR 26 Solvent Weld Sewer Fittings

Injection Molded in Sizes 4" - 8"
Fabricated in Sizes 10" - 24"

The M series is a line of SDR 26 solvent weld sewer fittings that has been engineered to perform in the harshest environments. Our fittings are designed and manufactured to consistent dimensions and laying lengths to deliver a securely sealed, water-tight joint connection on every installation. Only virgin compounds are used in our injection molding process to ensure the highest quality and durability.

All fittings are thoroughly tested for joint tightness, internal stress and stability, color and uniformity. SDR 26 solvent weld sewer fittings conform to all municipal, federal, and military requirements and are available in a wide range of sizes.

Design Advantages

- Designed for easy assembly
- Highest quality materials for long lasting performance
- Consistent dimensions provide joint integrity
- Broadest offering in the industry

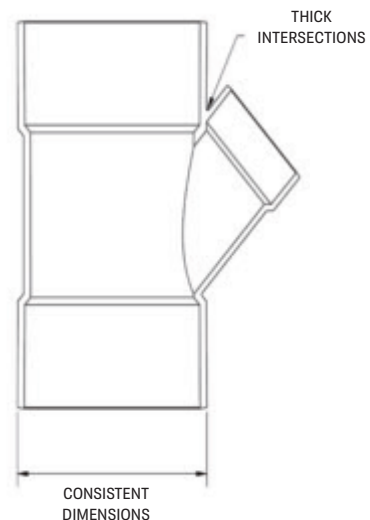

Applications

Non-pressure drainage of sewer and surface water wherever heavy SDR 26 is specified.

Typical Uses:

Drainage

- Municipal
- Commercial

Lateral Connections to Municipal Sewers

- Sanitary
- Storm

Surface Drainage

- Foundation drains
- Radon gas venting
- Yard drainage

Attention: Royal Building Product's fittings are not to be used or tested with compressed air or gases.

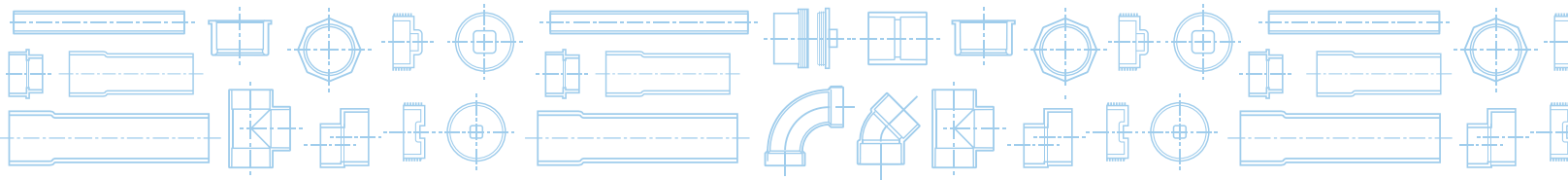

M-Series

The M series is an SDR 26 solvent weld sewer fitting line developed with structural integrity for high performance and easy assembly.



Short Form Specifications

4" through 12" injection molded solvent weld SDR 26 sewer fittings shall be manufactured in accordance with ASTM D3034, and CSA B182.2. They shall be injection molded from virgin PVC compound having a cell classification of 12454 or 13343 in accordance with ASTM D1784.

Certification

Our Solvent Weld SDR 26 Sewer fittings are manufactured to meet specs defined in ASTM D3034 and CSA B182.2.

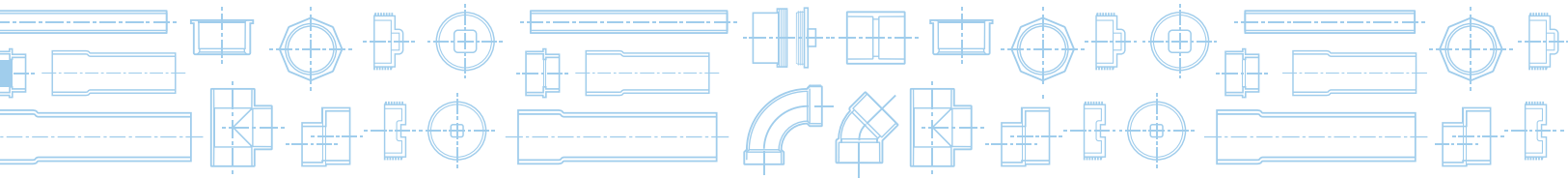

Vertical Riser System

Our Vertical Riser System has designed-in features that drastically reduce sewer system exposure to soil settlement issues, protecting the sewer line from top to bottom, while reducing excavation.

The integrated system is field-proven. A specially designed (CSJ) controlled settlement joint reduces sewer system exposure to soil settlement by adjusting to external forces exceeding 500 PSI. The riser adapter, CSJ, and deep socket elbow all work together to help eliminate fitting breakage.

The design of our vertical riser systems may include fittings from the G or H series.

Design Advantages

The addition of a Deep Socket Elbow allows earth compaction and settlement to occur with without pipe pulling out of the fitting socket as the installation settles. Pipe is fully inserted into the deep socket elbow allowing a full 6 inches of movement without disengagement.

The controlled settlement joint provides up to 5-1/2" of axial movement when encountering forces in excess of 500 lb/ft. Essentially, the Controlled Settlement Joint absorbs the forces exerted by compression allowing movement in the riser, potentially eliminating both internal stresses from pipe push through and external forces generated by compressive earth load conditions.

Vertical Riser Adapters prevent internal pipe push through or spearing, which can cause internal stress on fittings.

The combination of the Vertical Riser Adapter and Controlled Settlement Joint provides an extra measure of security against spearing.



Vertical Riser System

Applications

Used to connect laterals to sewer mains.

Attention: Royal Building Product's fittings are not to be used or tested with compressed air or gases.

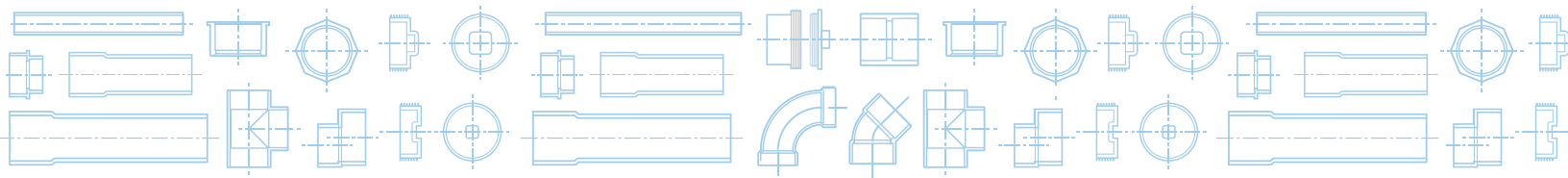

Sewer Riser

A group of components which can be configured to achieve a variety of vertical sewer riser systems to protect against settlement and compaction forces.



Controlled Settlement Joint GxG
G/H Series



Vertical Riser Adapter SxS
G/H Series



Deep Socket 1/4 Bend GxG
H Series

Short Form Specifications

Vertical Risers for Sewers shall contain a Controlled Settlement Joint, a Vertical Riser Adapter, and a Deep Socket fitting. SDR 26 pipe and other SDR 26 fittings are required for directional and transitional connections. Controlled settlement joints used in a vertical riser system shall provide a minimum of 5 1/2 inch of axial movement when forces of 500 pounds or greater are applied and shall be fabricated from pipe which is manufactured to ASTM D3034 specifications.

A molded SDR 26 Vertical Riser Adapter shall be installed between the Controlled Settlement Joint and the bottom transition fitting, as per Royal technical bulletin form #1060. A molded, where available, SDR 26 Deep Socket sewer fitting shall be used at the top of each riser assembly. SDR 26 Deep Socket fittings shall provide a minimum socket depth of 6 1/2" below the fitting gasket race. All fittings used in the vertical riser system shall be SDR 26, where available, and manufactured in accordance with ASTM D3034 and F1336. Molded fitting gaskets shall comply with the ASTM F913 or F477.

Molded fitting gaskets shall be locked firmly in position with a green color-coded retention ring for easy identification and to prevent displacement. Molded fitting gaskets shall be listed by NSF in compliance with the requirements of ASTM D3212. SDR 26 molded fittings shall be listed by NSF. Molded fittings shall be injection molded from virgin PVC compound having a minimum cell classification of 12454 in accordance with, and certified by NSF, to meet ASTM D1784. Vertical Riser Systems for Sewers shall be assembled per Royal Building Products recommended specifications, bulletin Form #1090.

Certification

Our injection molded SDR 26 gasketed fittings are third party tested and listed by NSF, and CSA to meet specifications defined in ASTM D3034, ASTM F1336 and CSA B182.2, where applicable.



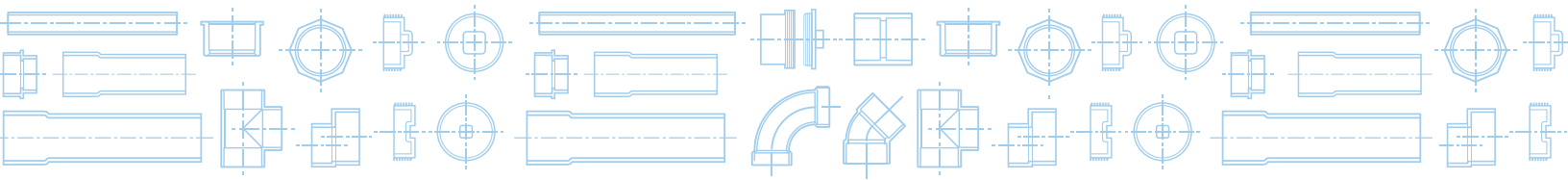

I.P.S. Gasketed Gravity Drainage Fittings

Injection Molded in Sizes 4" - 8" Fabricated in Sizes 10" - 24"

The T series is a line of SDR 26 (Class 160) gasketed drainage fittings engineered to accommodate applications requiring Class 160, I.P.S. pipe for gravity drainage. The fittings are designed for maximum performance in the toughest environments with a superior, high impact retention ring.

The gasket and shock absorbing properties of the gasket retention ring combine to reduce the effect of impact on 4" to 8" sizes for a more resilient system. A special collar design permanently locks the gasket into the fitting ensuring a secure fit. It also ensures a robust seal preventing infiltration and ex-filtration. To make it easy to identify in the field, the collar and ring are a distinctive blue color.

A deep lead into the gasket enhances assembly and reduces the possibility of gasket damage or rolling, and our square pipe stop resists pipe push-through from over insertion.

Design Advantages

- Heavy duty, shock absorbing collar designed to permanently lock the gasket onto the fitting and inhibit fitting breaking under impact
- Reinforced wall thickness at key branch intersections for added strength. Injection molded joint withstands 200 psi hydrostatic pressure and 22" mercury vacuum pressure
- Specially-designed square pipe stop prevents damage from over insertion, requires 30% more force before spearing
- Distinctive blue high impact retention rings and gaskets for easy identification in the field

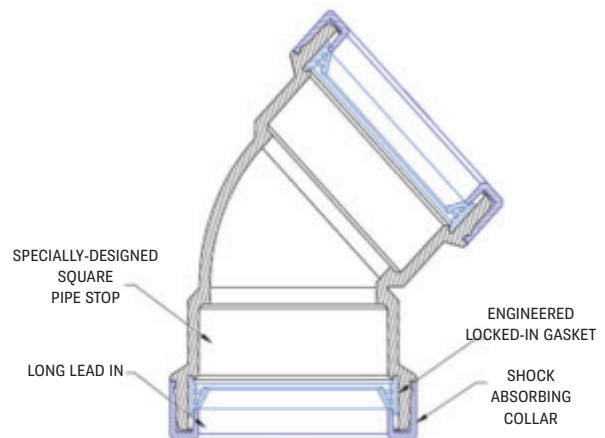

Applications

Gravity drainage of sewage and surface water where I.P.S. pipe is specified.

Typical Uses:

Lateral Connections to Municipal Sewers

Sanitary
Storm

Surface Drainage

Area drainage
Parking lot drainage

Attention: Royal Building Product's fittings are not to be used or tested with compressed air or gases.

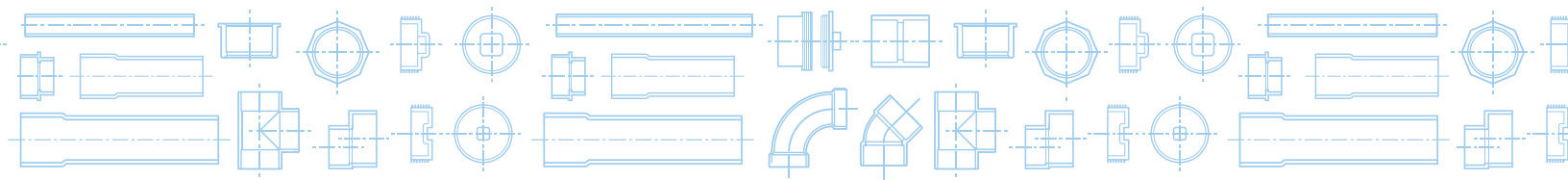

T-Series

The T series fitting line is a fully-integrated I.P.S. (Class 160) drainage fitting designed for structural integrity of the installation and provides long-lasting performance. It can be easily recognized by its blue retention ring and gasket



Short Form Specifications

4" - 8" fittings molded or assembled from molded components have a distinctive blue locking collar and gasket for easy identification. Inspected in accordance with ASTM D2122 and made from PVC material that conforms to ASTM D1784 with a cell class of 12454, Type 1, Grade 1. Minimum wall thickness meets or exceeds the requirements of ASTM D2241 SDR 26 (Class 160) and ASTM D2665 Schedule 40 DWV. The elastomeric joints conform to ASTM F477 and the performance requirements of ASTM D2241. Fittings have been certified as meeting a 160 PSI Pressure Rating in accordance with Table X1.1 of ASTM D2241. Gasketed joints are listed by NSF as meeting the requirements of ASTM D3212 in straight alignment, angular deflection and top load deflection for joint tightness at 200 PSI and vacuum at 22" mercury.

10" - 24" Fabricated fittings are produced from SDR 26 (Class 160) pipe which meets or exceeds all of the specifications of ASTM D2241. Produced from pipe made from material that conforms to ASTM D1784 with a cell classification of 12454, Type 1, Grade 1. Fittings inspected in accordance with ASTM D2122. Gasketed joints conforms to the performance requirements of ASTM D3139 section 8.1.1.

Certification

Our Gasketed Molded I.P.S. Drainage fittings are third party tested and listed by NSF to meet specifications defined in ASTM D2665 and ASTM D2241, where applicable.



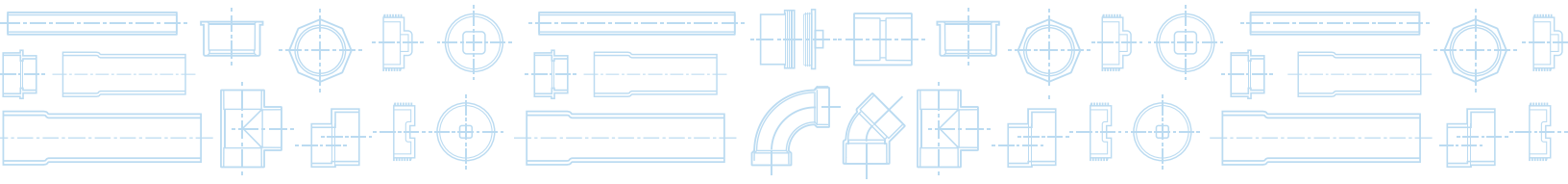

C.I.O.D. Gasketed DR18 & DR25 Pressure Fittings

Fabricated in Sizes 10" - 36"

The C series line of DR18 & DR25 gasketed pressure fittings is for CIOD applications. Our C900/905 fittings are designed to be used with engineered joint restraints or concrete thrust blocking. They are a tough alternative to cast iron fittings, but have the benefit of being resistant to corrosion because they contain no metallic parts. Our fittings contain the same long-term hydrostatic strength as our CIOD pressure pipe.

The gasket ensures watertight joints with virtually no risk of infiltration or leakage. Only pure clean water that enters the system, leaves the system. A standard bell OD facilitates joint restraint installation while allowing all fittings to have fiberglass reinforced wrap, where required, for added strength.

Bends of 45 degrees or less are manufactured of one-piece construction, where available, providing a lightweight, compact fitting which can easily be handled in the field.

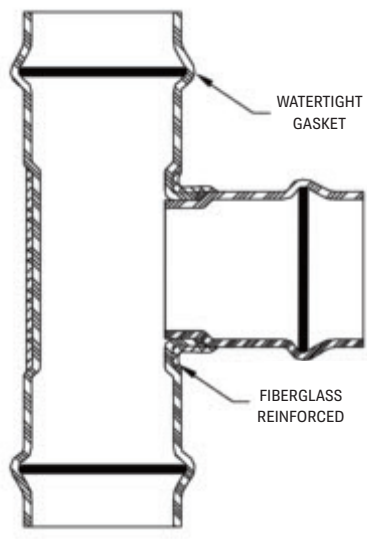

Design Advantages

- Corrosion-resistant
- Thermoformed, glued and fiberglass reinforced, where required
- Watertight gasket for system integrity
- Durable, easy to install and long lasting

Applications

Used in both higher pressure water systems and low pressure sewer force main systems.

Typical Uses:

- Potable water supply
- Municipal water mains
- Fire lines
- Industrial process lines
- Sewer force mains

Attention: Royal Building Product's fittings are not to be used or tested with compressed air or gases.

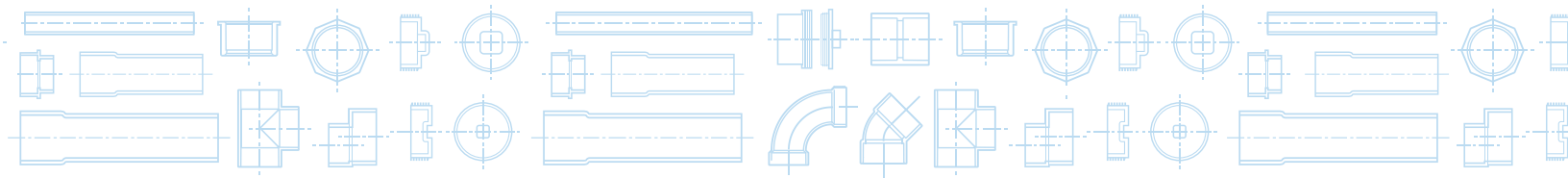

C-Series

C series fittings are a fully-integrated DR18 & DR25 fitting line used for connections with CIOD. Fully reinforced with fiberglass wrap, where required, and designed for easy installation.



Short Form Specifications

Fabricated fittings 10" and greater shall conform to the requirements of AWWA C900 and C905. Fabricated fittings shall have a dimensional ratio equal to that of the pipe they are being installed on. All PVC CIOD fittings shall incorporate integral elastomeric gasket bell joints. Materials used in the manufacture of PVC fittings shall equal or exceed cell class 12454 (ASTM D1784) with a hydrostatic design basis of 27.58 Mpa at 23°C as outlined in AWWA C900 and C905. The compound shall be listed with the National Sanitation Foundation. Fabricated fittings shall be manufactured from segments of PVC pipe bonded together and over wrapped with fiberglass-reinforced polyester, where required, to the requirements of AWWA C900 and C905. All bends, up to and including 45°, shall be constructed from a single section of PVC pipe, without joints, bonding or fiberglass-reinforced polyester wrapping, where available.

Note: Where the bends 45° or less are one piece, fiberglassing is redundant and can be eliminated. The pressure rating of the fittings shall be equal to the pressure rating of the pipe they are being installed on. All fittings shall be marked with the following identifications: Nominal size, CIOD, Manufacturer's name or trademark, AWWA pressure rating, pressure class and standard number to which the fitting is made, and an indication of potable water use, potable, P, PW and proper handling label.

Certification

Our Pressure C.I.O.D. Gasketed Sewer fittings conform to AWWA C905.

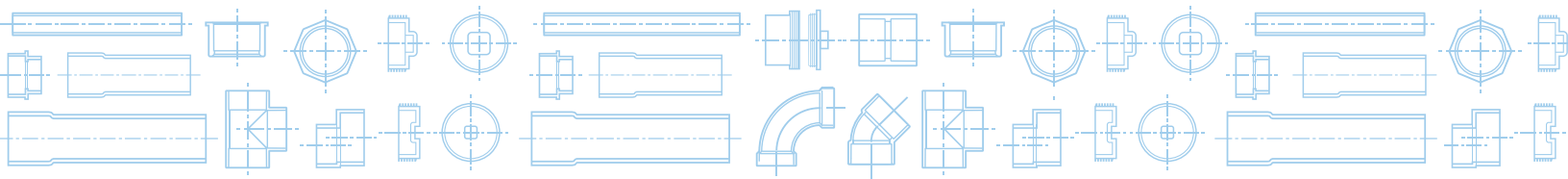

C.I.O.D. Gasketed DR25 Non-Pressure Fittings

Fabricated in Sizes 4" - 36"

The N series line of DR25 gasketed non-pressure C905 fittings is for use in CIOD applications. These fittings are a tough alternative to cast iron fittings. They have the benefit of being resistant to corrosion because they contain no metallic parts.

The locked-in gasket creates a tight seal which protects the pipe and fittings from shock, vibration and earth movements. The gasket also ensures watertight joints with virtually no risk of infiltration or leakage.

Fabricated bends of 45 degrees or less are manufactured from one piece of pipe, where available, providing a lightweight, compact fitting which can easily be handled in the field.

The N Series does not include fiberglass reinforcement due to its non-pressure application.



Design Advantages

- Corrosion-resistant
- Watertight gasket for system integrity
- Durable, easy to install and long lasting

Applications

Used for sewer and drain applications. Most commonly installed in either areas of high water tables or extremely deep burials.

Typical Uses:

Drainage

- Sewer main systems
- Industrial process drainage lines

Attention: Royal Building Product's fittings are not to be used or tested with compressed air or gases.

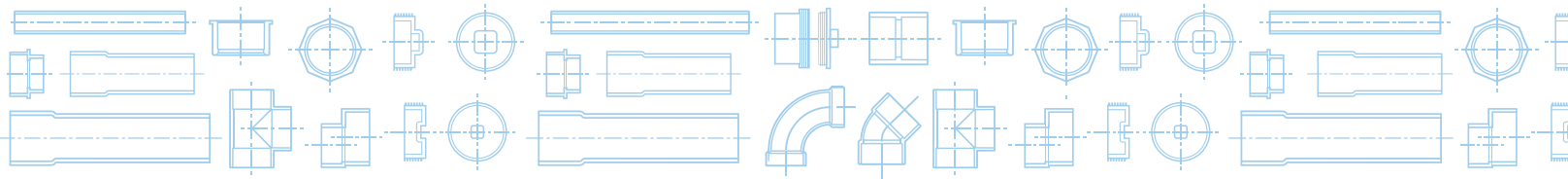

N-Series

The N series fitting line is a fully-integrated DR25 fitting line used for connections with CIOD applications.



Short Form Specifications

Sizes 4" through 36"

CIOD Non-Pressure fittings shall conform to the dimensional requirements of AWWA C900 and C905. DR25 Non-Pressure Fabricated fittings may be used with any CIOD DR ratio pipe. All PVC CIOD fittings shall incorporate integral elastomeric gasketed bell joints. Materials used in the manufacture of Non- Pressure PVC fittings shall equal or exceed cell class 12454 (ASTM D1784). Fabricated fittings shall be manufactured from segments of PVC pipe meeting the requirements of AWWA C900 and C905. Non-Pressure CIOD fittings do not require any fiberglass wrap and are not marked with any pressure rating.

PVC fittings shall be able to withstand 10.8 PSI internal pressure and 22" mercury vacuum for joint tightness in accordance with ASTM D3212.

All fittings shall be marked with the following identification:

- Nominal Size
- Non-Pressure CIOD
- Suppliers Name or Trademark

Certification

Our Non-pressure C.I.O.D. Gasketed Sewer fittings conform to portions of AWWA C905.

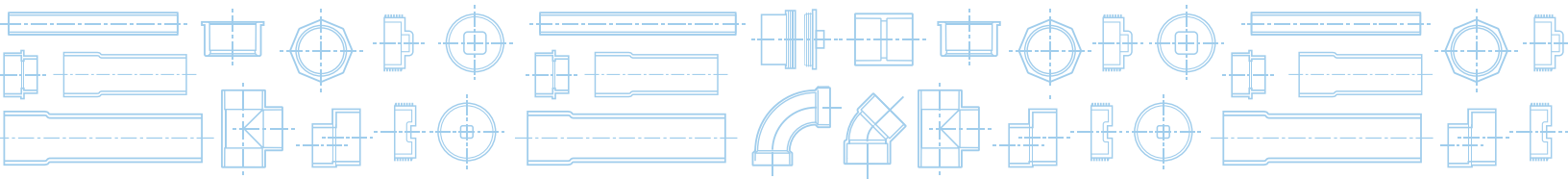

SDR 35 PVC Profile Sewer Fittings

Fabricated in Sizes 8" - 36"

The K Series is a complete line of SDR 35 fabricated fittings geared to work with ribbed pipe. Our fittings are designed for maximum performance in the most demanding environments and ease of installation. Construction from smooth wall SDR 35 pipe provides superior flow.

They are designed and manufactured to consistent dimensions and laying lengths to deliver a securely sealed, water-tight joint connection on every installation.

All fittings are thoroughly tested for joint tightness, internal stress, stability, color and uniformity. SDR 35 sewer fittings conform to all municipal requirements and are available in a wide range of sizes.

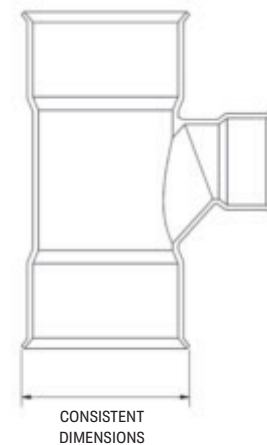

Design Advantages

- Corrosion-resistant
- Durable, easy to install and long lasting
- Versatile
- Pipe-specific gaskets supplied for every fitting
- Adapters available to make connections to other types of pipe systems including laterals, sewer stubs and sewer and storm mains

Applications

Used with Ultra Rib, KOR FLO, Ultra Corr, and many other types of PVC and poly ribbed pipe.

Typical Uses:

Lateral Connections to Municipal Sewers

Sanitary
Storm

Surface Drainage

Area drainage
Parking lot drainage

Attention: Royal Building Product's fittings are not to be used or tested with compressed air or gases.

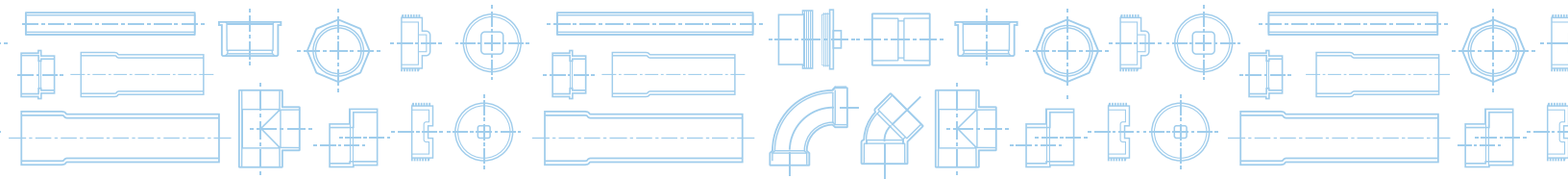

K-Series

The K series is a line of fully-integrated SDR 35 fittings used for connections with ribbed pipe.



Short Form Specifications

This specification covers the requirements for Fabricated PVC (polyvinyl chloride) Profile Sewer Fittings, 8" through 36". These fittings are manufactured to meet ASTM F794. The fittings include: tees, wyes, tee-wyes, double wyes, crosses, bends, couplings, repair couplings, increasers, caps and plugs.

The fittings are fabricated from SDR 35 Sewer Pipe which meets ASTM D3034 and F679. The joints for these fittings comply with ASTM D3212 joint tightness requirements for up to 5° of angular deflection.

Markings on the fittings are as specified in ASTM F794 and tested in accordance with ASTM F794.

Certification

Our PVC Profile Gasketed Sewer fittings conform to ASTM F794.

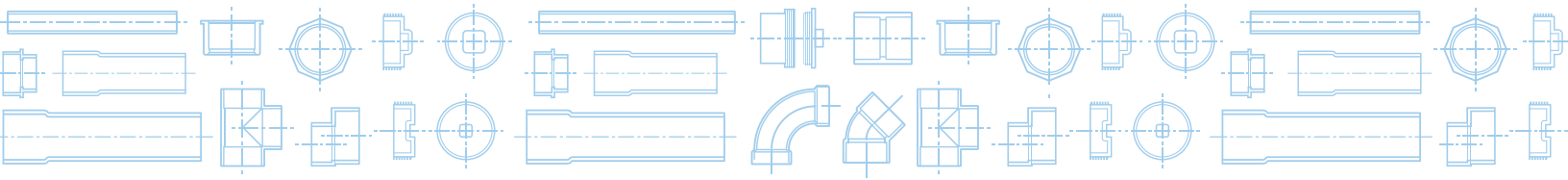

PVC Backwater Valves

Injection Molded in Sizes 4" - 6" Fabricated in sizes 4" - 27"

PVC Backwater Valves are designed to prevent fluids from re-entering drainage systems, should backflow occur. Unidirectional flow through the valve is created by a flap that freely opens during outflow, and is trapped closed if backflow occurs.

Our injection molded valves come complete with leak free neoprene gaskets on the flapper and lid for maximum performance. In line Backwater Valves in 4" and 6" are designed and assembled from molded components. Two configurations are available; In line Backwater Valves and Terminal Backwater Valves.

Designed to integrate with Series G, D and P fittings.

Design Advantages

- Durable, easy to install and long lasting
- Easy to remove threaded lid makes inspection simple and quick
- Wide range of sizes

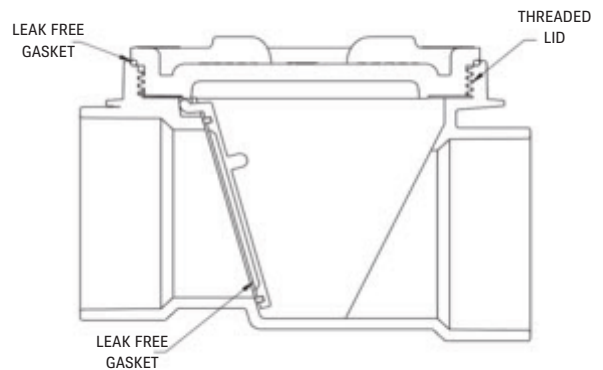

Applications

Used to prevent backflow at the end of sewer lines or overflow from a sanitary sewer pumping station. Also used with storm sewer retention ponds.

Typical Uses:

Onsite Disposal

- Closed loop septic fields
- Open septic fields
- Engineered systems

Lateral Connections to Municipal Sewers

- Sanitary
- Storm

Surface Drainage

- Foundation drains
- Yard drainage

Attention: Royal Building Product's fittings are not to be used or tested with compressed air or gases.

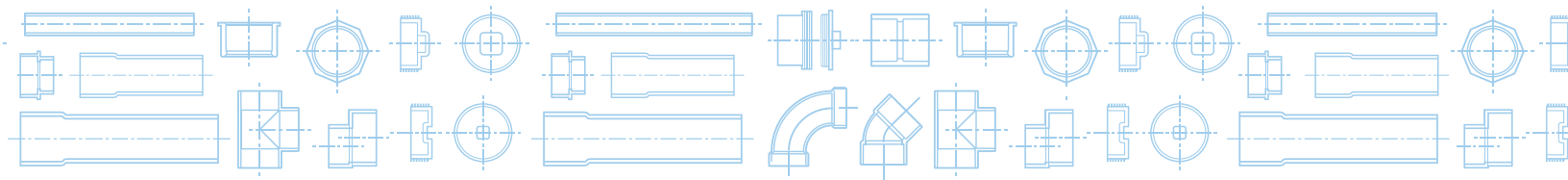

Backwater Valves are available in Terminal or In line designs for use with G, D and P Series Fittings.



Short Form Specifications

Our 4" & 6" Backwater Valves are designed for use with DWV Schedule 40 pipe (ASTM D2665). If an adaptation to sewer pipe is desired, adapter sleeves may be used to accept SDR 35 sewer pipe (ASTM D3034). 4" and 6" injection molded Backwater Valves are listed by NSF and IAPMO. The 4" Backwater Valve is designed to accept an access sleeve of either 8" DWV pipe (ASTM D2665) or 8" SDR 35 sewer pipe (ASTM F3034). The 6" Backwater Valve is designed to accept an access sleeve of either 10" DWV pipe (ASTM D2665) or 10" SDR 35 sewer pipe (ASTM D3034), eliminating the need for special sleeves. Backwater Valve and access sleeve must be properly bedded and compacted in accordance with Uni-Bell recommendations.

Operation and Installation – In order to ensure continuous proper function of Backwater Valves, please review the following guidelines:

- Valve is to be installed in a nominally horizontal line only, with no more than 1/4" per foot of slope. The access plug is to be in the vertical orientation.
- The valve should be installed with direction of flow, as indicated by the directional arrow on the outside of the valve.
- Care must be taken to keep solvent cement out of the valve body when making solvent weld connections. Flap should be tested for freedom of movement and proper seating after solvent weld connections have thoroughly cured.
- To ensure proper flap function, threaded cap must be securely tightened.
- It is recommended that the Backwater Valve be periodically inspected for proper function, to ensure that no solid matter has become trapped between the flap and the valve body.



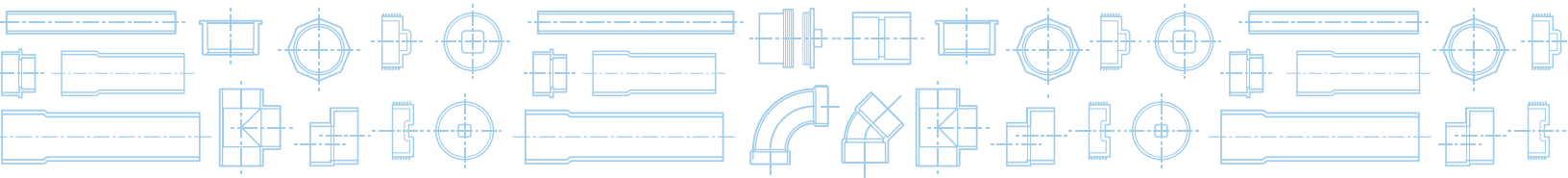

DWV Solvent Weld Fittings

Injection molded in 4" - 12"
Fabricated sizes 10" - 24"

The D Series is a complete line of Solvent Weld DWV Schedule 40 fittings used in drain, waste and vent applications. Engineered to perform in the harshest environments and designed and manufactured to consistent dimensions, these fittings deliver a securely sealed, water-tight joint connection on every installation. Only virgin compounds are used in our injection molding process to ensure the highest quality and durability.

All fittings are thoroughly tested for joint tightness, internal stress and stability, color and uniformity. Our solvent weld DWV fittings conform to all municipal, federal, and military requirements and are available in a wide range of sizes.

PVC backwater valves are designed to be integrated with this series.

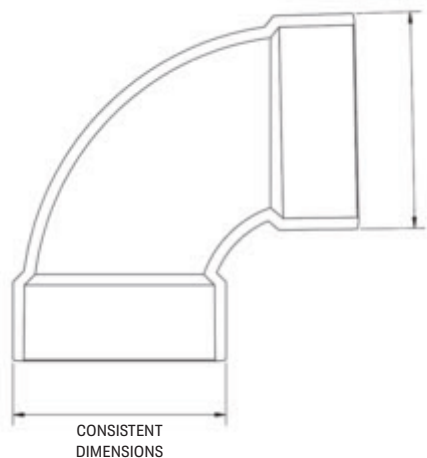

Applications

DWV applications connecting to Schedule 40 pipe.

Typical Uses:

Drainage

- Commercial or industrial
- Parking deck
- Bridges
- Roof
- Sewer connections

Sewer connections

Attention: Royal Building Product's fittings are not to be used or tested with compressed air or gases.

Design Advantages

- Consistent and accurate dimensions for easy installation saving jobsite labor
- Designed to fit DWV Schedule 40 pipe
- Durable and long lasting
- **Triple certification listing**

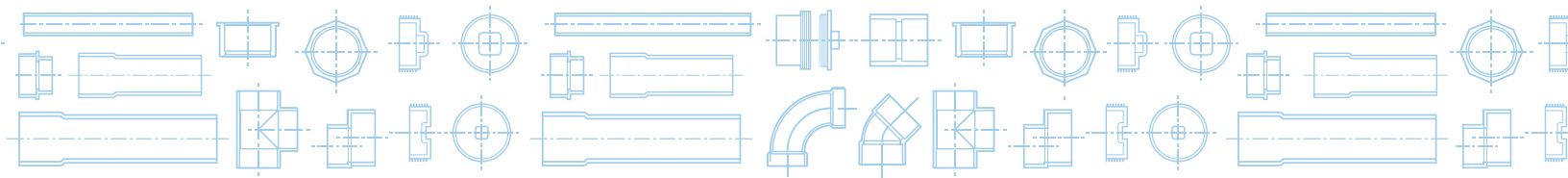

D-Series

The D series is a complete line of DWV fittings designed for use with Schedule 40 or DWV pipe applications.



Short Form Specifications

4" through 12" injection molded solvent weld Drain, Waste, and Vent (DWV) fittings shall be manufactured in accordance with ASTM D2665, F1866, F2135, and CSA B181.2, as applicable. Solvent weld DWV fittings shall be certified by the National Sanitation Foundation (NSF) to meet ASTM D2665, F1866, and ASTM F2135, as applicable; and by the Canadian Standards Association (CSA) to meet CSA B181.2 as applicable. They shall be certified by the International Association of Plumbing and Municipal Officials (IAPMO) to meet the requirements of the Uniform Plumbing Code (UPC), as applicable.

Certification

Our solvent weld DWV molded fittings are third party tested and listed by NSF, UPC and CSA to meet specifications defined in ASTM D2665, ASTM F1866 and CSA B181.2, where applicable. Fabricated fittings conform to ASTM F1866.



E-Series Electrical Fittings and Components

Royal is pleased to offer a broad portfolio of complementing PVC electrical solutions. These fittings are designed and tested to the same extremes as our municipal and plumbing products so that you are guaranteed a quality product.

Custom Enclosure Boxes - NEMA 4X and ETL Rated.
Lightweight and watertight enclosures that offer heavy duty performance while providing easier installation and reduced life cycle costs.



Corrosion resistant and non-conductive. Size and pre-punch cutouts to your specifications. For applications where internal wiring needs to be protected from exposure to water, liquids and debris.

Rigid Conduit Fittings - UL and CSA Listed. Lightweight, durable and concrete tight. Non-metallic and non-corrosive. A complete assortment of gang boxes, entrance fittings, access fittings, couplings and Schedule 40 and 80 elbows.



Designed to integrate with Rigid conduit for commercial and industrial applications.

ENT Fittings and Tubing - UL Listed. A family of fittings and flexible pipe that can be used in many applications. Fittings are designed with external removable and replaceable clip rings for a concrete tight fit.



Flexible corrugated conduit is lightweight and durable. Used in electrical raceways in encased concrete and direct burial applications.

Our Warehouse Locations

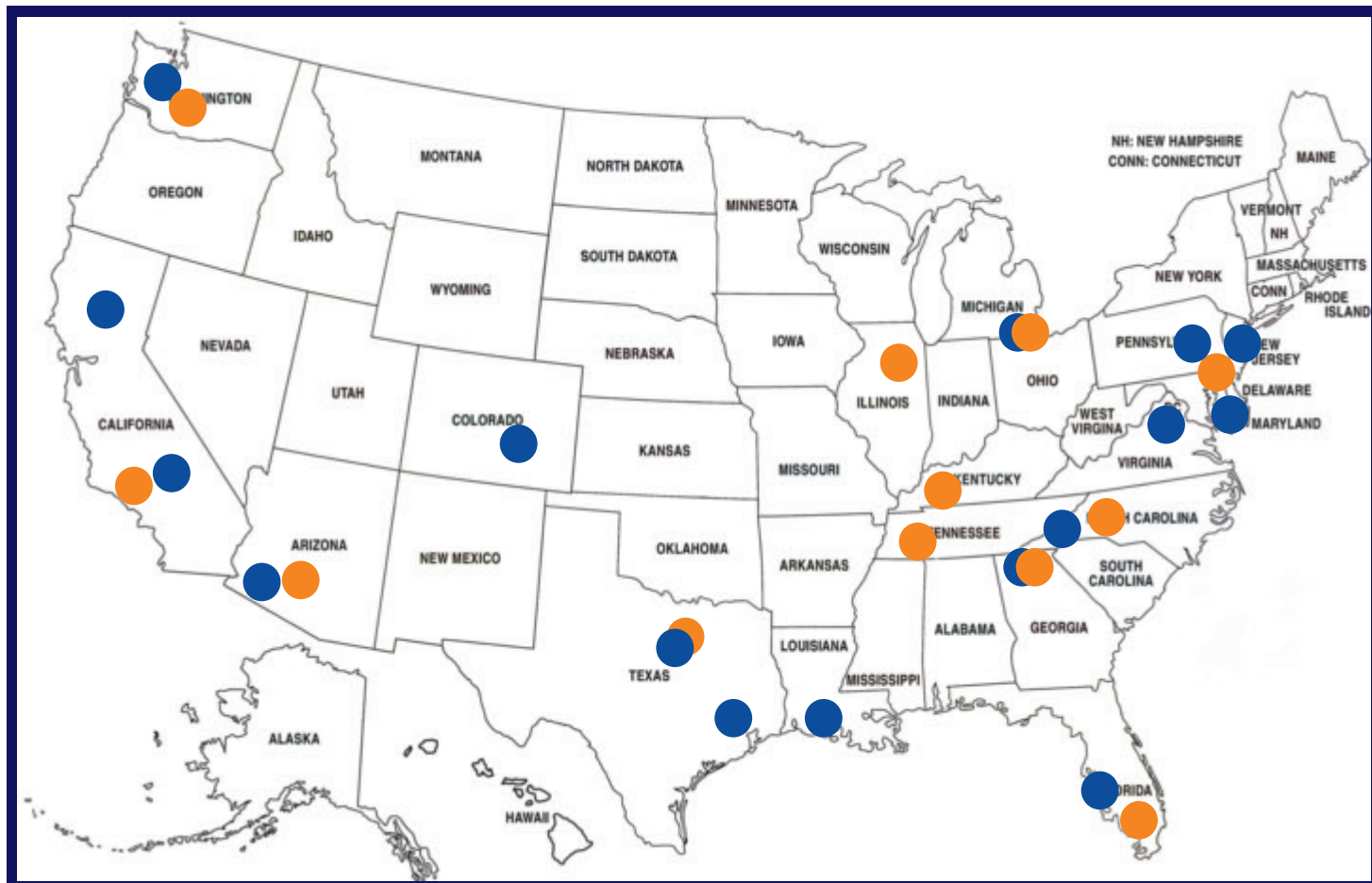

● Municipal/Plumbing Products

● Electrical Products

Sales & Distribution Center:

Royal Building Products
56400 Mound Road
Shelby Twp., MI 48316
T 1.800.232.5690
F 586.781.0888

royalbuildingproducts.com

Attention: Royal Building Product's fittings are not to be used or tested with compressed air or gases.

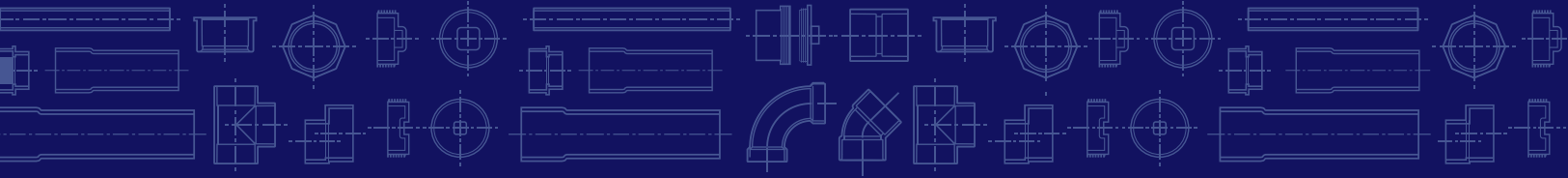

Our various pipe and fittings solutions have been manufactured to meet the needs of our customers and their applications. Contact the below Sales Center for more information.

- Municipal Pipe & Fittings Solutions
- Plumbing Pipe & Fittings Solutions
- Industrial Pipe & Fittings Solutions
- Electrical Pipe & Fittings Solutions

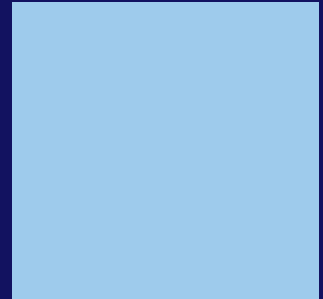

Sales & Distribution Center:

Royal Building Products
56400 Mound Road
Shelby Twp., MI 48316
T 1.800.232.5690
F 586.781.0888

.....
royalbuildingproducts.com

Pub No. 1303M
May 2014
Printed in USA



Pipe & Fittings Solutions | Municipal Plumbing Industrial Electrical